

OPERATION MANUAL

Thanks for your kind attention for our 520 Vertical Packing Machine, which belongs to Automatic Vertical Packing Sealing Machine. The 520 type has reasonable fabrication, fine characteristics, nice out shape, good stability and reliable safety etc advantages. Hope our 520 Vertical Packing Machine will bring your greatest conveniences after your use.

Please read this Operation Manual carefully before using the packing machines, which will definitely help you to know well their basic performances, structure, operation and maintenance methods, so as to make correct use and maximize the performance, reduce failure and prolong the operational time. During the trial run, the operator should learn how to use the machine as soon as possible under its instructions.

Innovative technology, outstanding quality win customers` consent and trust constantly. Please be a close cooperative partner with MOTECHPACKING Machinery Co., Ltd.

OPERATION MANUAL

CONTENTS

Preface	4
1 Safety operation of this machine	4
2 Usage and advantages	6
1. suitable range	6
2. main specification and technical parameters film	6
3. Film parameters	7
3 Installation and test	9
1. Installation	10
2. Dismantle and install	11
3. Install the hopper	15
4. Air inlet	15
5. Power connection	16
6. Verification and correction	17
7. Clearance	17
4 Adjustment and operation procedure	17
1 . control panel	17
2 . menu	18
3 . install and debug the packing film	22
(1) loading the film	22
(2) regulating paper tensility	24
(3) adjusting central sealing	25
(4) using photoelectric eye tracking system	26
(5) notes for adjusting bag former	26
(6) notes for end sealing	27

OPERATION MANUAL

(7) adjusting for vertical sealing guider	27
(8) adjusting for date prin	28
5. Regular start	29
6. Maintenance and service	30
7. Troubleshooting.....	31
8. Rejection treatment.....	31

Appendix:

OPERATION MANUAL

Preface

Please read this Operation Manual carefully before using the packing machines, which will definitely help you to know well their basic performances, structure, operation and maintenance methods, so as to make correct use and maximize the performance, reduce failure and prolong the operational time. During the trial run, the operator should learn how to use the machine as soon as possible under our instructions.

— Safe operation of this machine

- 1 To make sure there is no tool or any impurity on the operation surface, conveyer belt or sealing tool carrier and no abnormality around the machine before starting.
- 2 Protection equipment is in function position before start.
- 3 Forbid to put hands and tools into end sealing tool carrier during operation of the machine!
- 4 Forbid to close to any operating part during operation of the machine!
- 5 Forbid to switch the operation buttons or change parameter setting frequently during its normal work.
- 6 No over speed long-time operation.
- 7 Forbid to operate the switch buttons and framework by more than two persons. Make sure to turn off the power while in maintenance. The operators should communicate with each other when the machine is debugged or maintained by several operators at one time so as to avoid any accident.
- 8 Cut the power while inspecting and maintaining the control circuit! It should be done by professional electrical operators. As the auto program locked, no one could modify it without any authorization.
- 9 Forbid to operate, debug or maintain by the people who are not clear because of drunk or fatigue. Other untrained or unqualified person could not operate the machine either.
- 10 Do not modify the machine without our permission. Do not use the machine outside the designated area.

OPERATION MANUAL

11 The insulated resistance and earthing resistance of this machine conform to national safety standard. On first start or not used for a long time, please use the heater at low temperature about 20mins to prevent the heating parts from damping.



Warning: For the sake of yourself and the others as well as the equipments, please operate as above. Our company takes no responsibility for any accident caused by failure to follow the above requirements.

二 Usage and advantages

1 suitable range

This machine is suitable for packing all kinds of granule materials, short strip and solid food, such as pop food, shrimp strip, peanuts, popcorn, cornmeal, melon seeds, jelly, white sugar, salt, laundry powder and so on.

2 main specification and technical parameters

1 packing speed	15-70 packs/min	
2 width of film	180-520 (mm)	
3 bagging size	L 80-300 (mm)	W 80-200 (mm)
4 total power	3 kw	
5 heating power	M-seal 0.7 kw	E-seal 1.2 kw
6 weight	580 kg	
7 noise	<= 75 db	
8 compressed air quantity	6kg/m2	0.3m ³ /min
9 power type	220v, 50Hz	
10 applicable packing materials:	OPP ·PE ·PVC · OPP/CPP ·OPP/PE ·PET/VMPET/PE	

OPERATION MANUAL

3. Film parameters

3.1 Film materials

520 Vertical Packing Machine suits for various plastic materials, for instance OPP/OPP、OPP/CE、MST/PE、PET/PE etc. Customers should purchase the film (Figure-1) based on the following film dimensions, outside diameter $\leq 400\text{mm}$ 、inside diameter $\Phi 75\text{mm}$, and the thickness for the laminated wrapping film $0.05\text{-}0.08\text{mm}$. Customers can print what they need in the printing area (Figure-2)

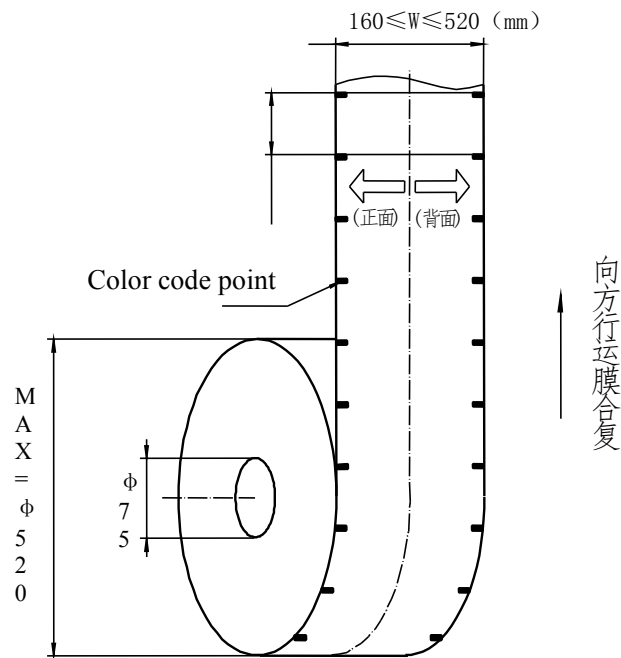

Figure-1 Film diagram

OPERATION MANUAL

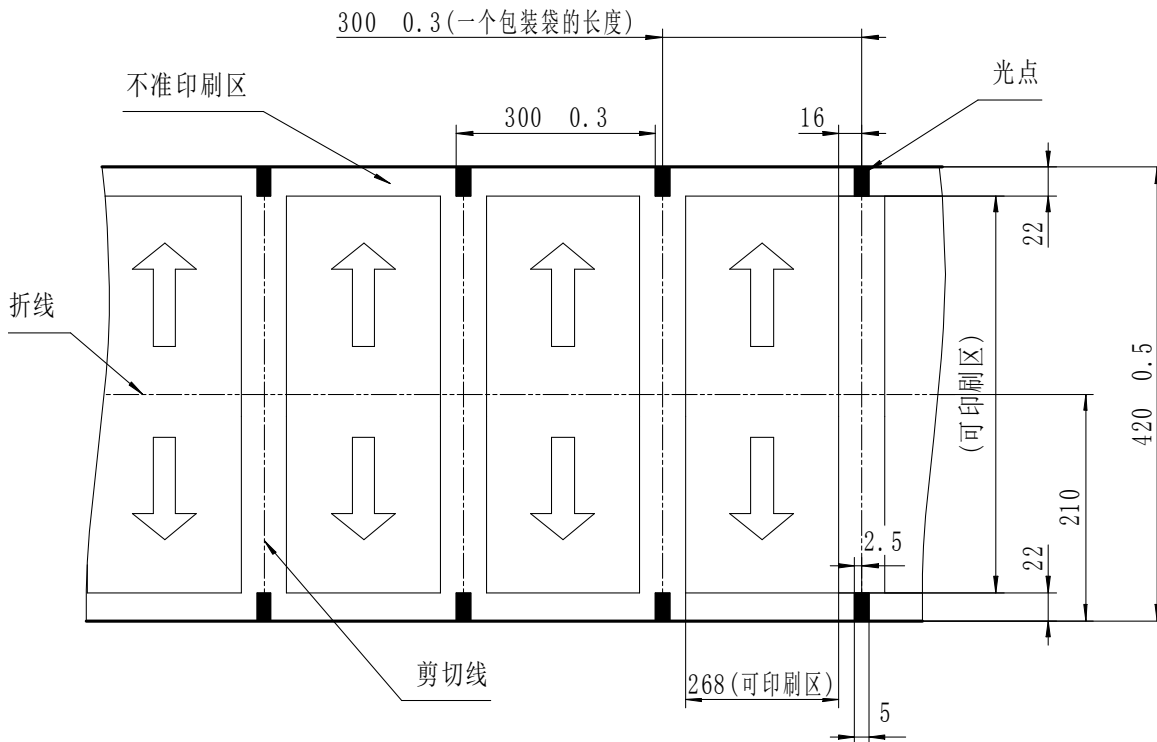

Figure-2 Film print diagram



Attention : when the film becomes curl, the surface must be neat without any waves, there`s no any words, veins within 10mm edges(the grounding color should be pure). And the color code point should contrast with the grounding color greatly

3.2 Sealing temperature of the film:

The sealing temperature should be fixed as per to different materials, thickness, and the instant packing speed. That means the exact sealing temperature couldn`t be introduced in details, only be adjusted properly during the operation



Attentions: different width for various film have different printing areas , if you need it, please inquire us directly

OPERATION MANUAL

三 Installation and debugging

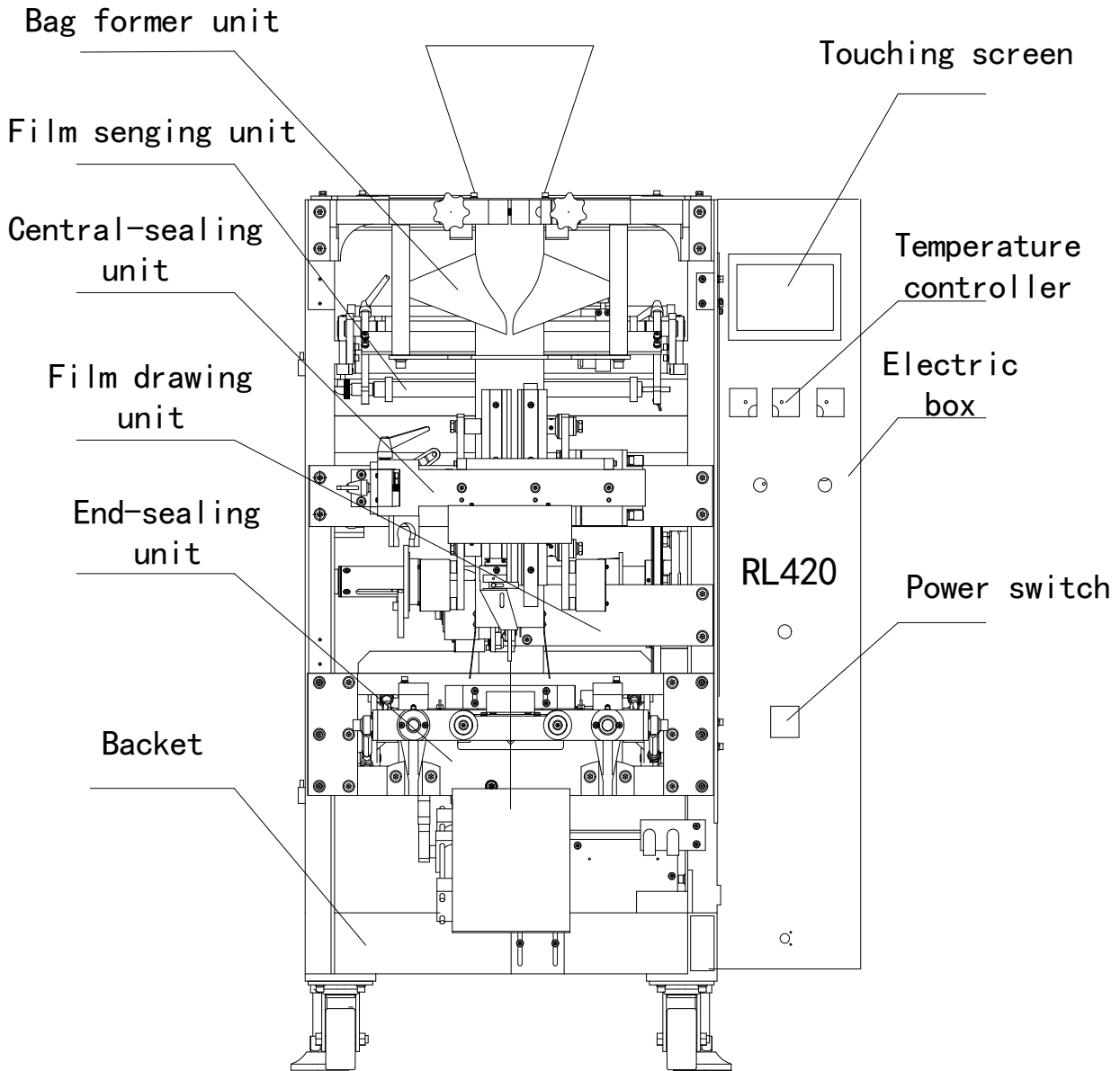

Figure-3.Main parts and related accessory of RL 520

1 Installation

Do not install the machine in the following places, otherwise it will affect its normal use.

(1) Non-level position

When place the machine on the level, please take the upper surface of sealing tool connecting base as the reference, and then put a gradienter on the reference surface, regulate the four feet adjusting screws at the bottom of the machine to make the reference keeping level and four feet wheels space.

(2) Under direct sunlight

The electric eye would fail if the machine is installed under direct or strong sunlight.

(3) Under excessively high or low temperature, or too narrow place.

Its suitable operation condition is, $0\sim 45^{\circ}\text{C}$, no coagulate water 10-90% RH.

(4) With vibration.

(5) Near the ventilated equipments and the exhaust hole of adjuster.

(6) Any corrosive gas or dust is not suitable for the machine's maintenance.

OPERATION MANUAL

2. Dismantle and installation

2.1 Dismantle

Put the packing machine box onto the working room's earth before dismantle in order to keep the machine balance. Open the upper-cover board of the packing machine box firstly, then dismantle the side board and take out the spare parts

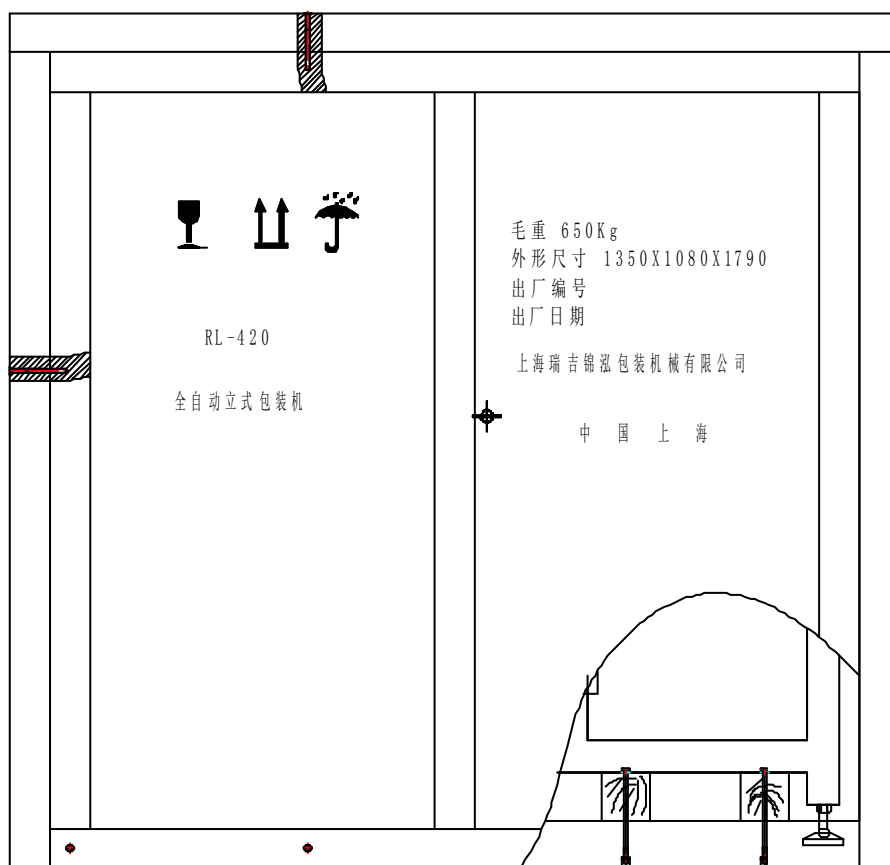

Figure-4 Packing machine box diagram

OPERATION MANUAL

2.2 Carry and installation



Attentions: the machine has a heavy weight, so be patient during the carrying and installing procedures. Please use the forklift or lift to move the machine

2.2.1 Installing requirement

The maximum installing sizes

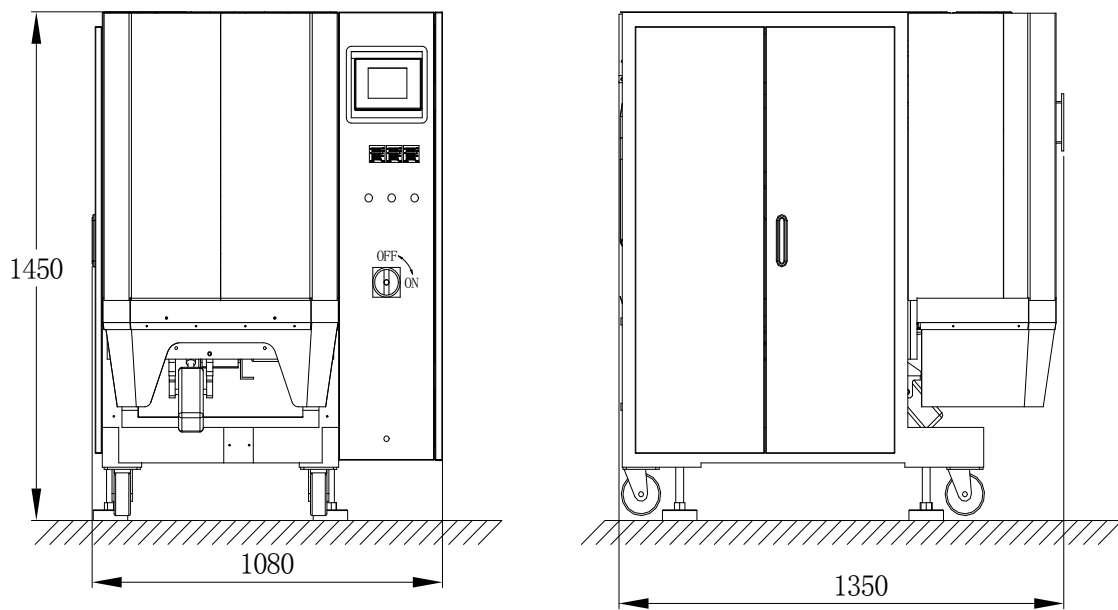

Figure- 5 Outside shape

OPERATION MANUAL

2.2.2 Installing program

The machine should be put on the solid and stable earth/surface. Non-dust environment is the best choice

2.2.3 Diagram for operational position of the workers

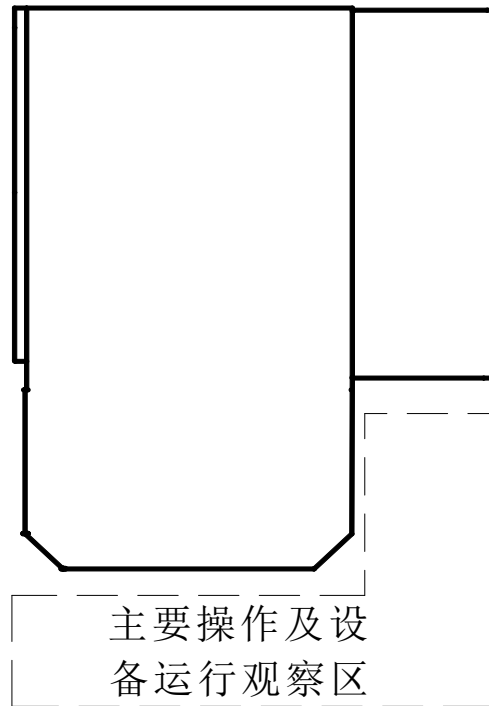

Figure- 6 Operational position diagram

OPERATION MANUAL

2.2.4 The necessary installing space

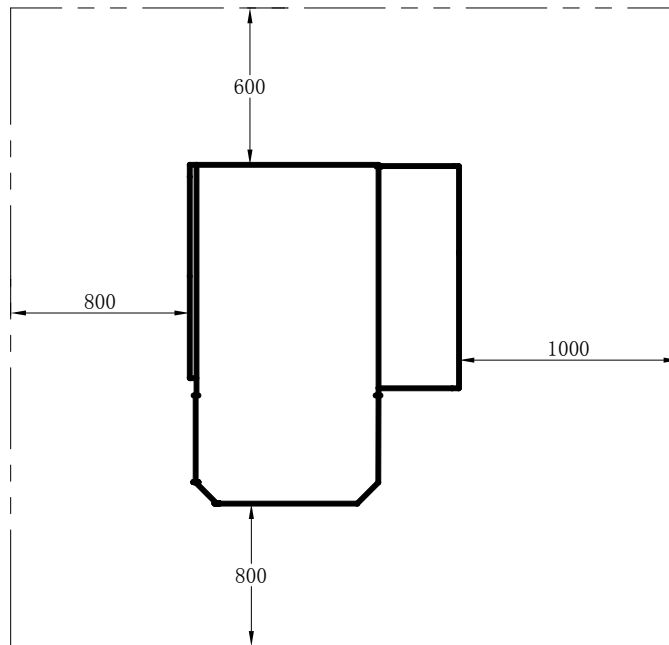

Figure-7 Safety space diagram

OPERATION MANUAL

3. Hopper installation

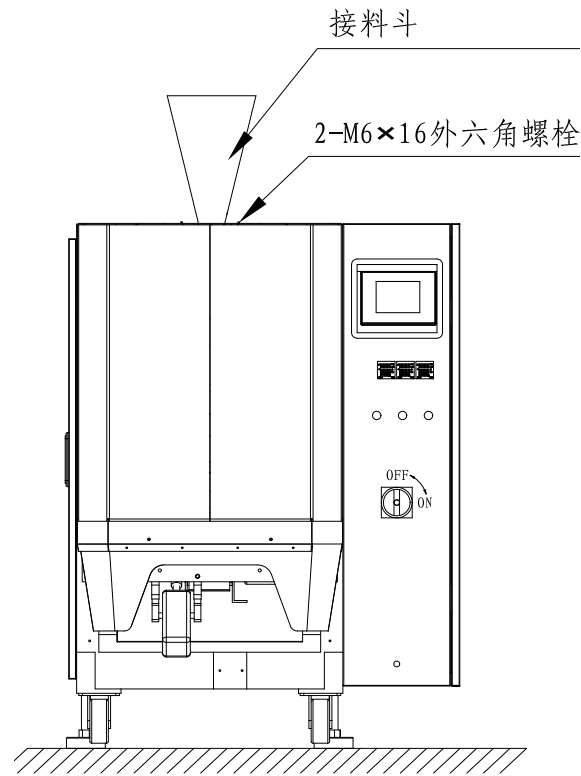

Figure-8 Hopper installation diagram

4. Air inlet

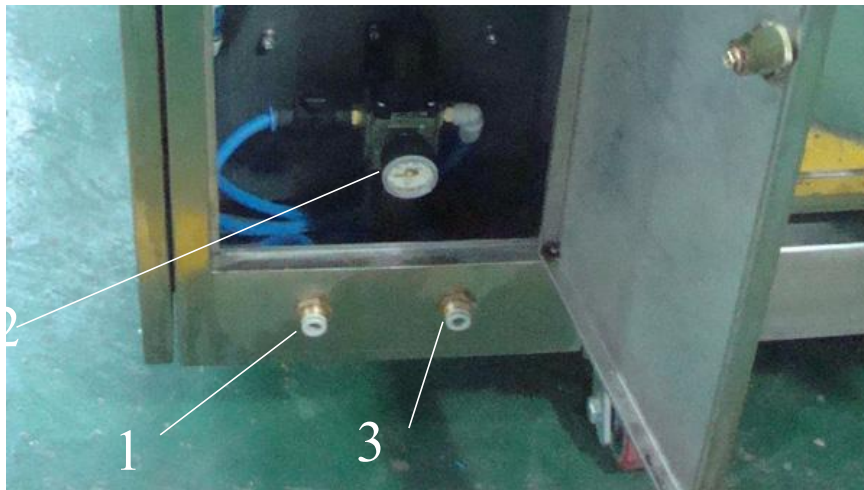

Figure-9 Air inlet diagram

1 —air inlet 2 —the pressure-valve adjuster 3. —spare inlet

Connect the air resources into the air inlet, and adjust the pressure valve. When the showing-watch cursor point at 6.5kg, it'll be correct

OPERATION MANUAL

5. Power connection



Attentions: Please must be careful during connecting the power.
Guarantee no other operations

5.1 connect the power

The power supply is 220V,50Hz/60Hz, please install the electricity according to the following steps.

(1) Take out the power wire of the electric box, one end insert into the tie-in(Figure-10)of the “main electrical box” on the back of the electrical box, and take off the protective cover of the main electrical box`s tie-in , then insert the power wire. Another end connect onto the 220VAC/27A power supply.

(2) Open the general power switch

Open the general power switch under the machine`s electric box (Figure-10)

1 — protective cover for the main electricity connection-mouth

2 — The symbol for the main electricity

3 — Main electricity connection-mouth

4 — Electricity plug wire



Figure-10 Power inlet diagram



Attention: Please check the breaker's voltage is 220V for one time power supply before connecting the electricity



Attention: Be sure that the machine has the earth conductor , and don't connect the earth conductor with other electric wires (check the pictures)

6. Verification and correction

Start the machine after assuring every component with correct installation

7. Clean

Must keep the machine clean and strict sanitation, which will be touched with the food before start the machine. Use the soft or tender cloth to rub the machine, if possible, use the cloth dripping the soap water to clean the carbon steel surface. And for the stainless steel or galvanized metal surface, alcohol is ok.

四 Adjustment and operation procedure

(1) Control panel

Control panel is in the middle of the right electric box, including two temperature controller for V-sealing and H-sealing, three buttons of “Start”. “Stop” and “Urgent stop”, and also the speed knob, as follows;

- 1 “Start” button: press it to start the machine.
- 2 “Stop” button: press it to stop the machine normally.
- 3 “Urgent stop”: press it to stop the machine immediately and lock automatically.

Turn right to restart.

The usage and operation methods of temperature controller

OPERATION MANUAL

Temperature controller is the apparatus for controlling the temperature, which could be continuously adjusted at the range of 0 to 399°C . The setting value is according to the packing speed, the thickness of packing film and the temperature around. No leak and no crinkle in two seals is most suitable

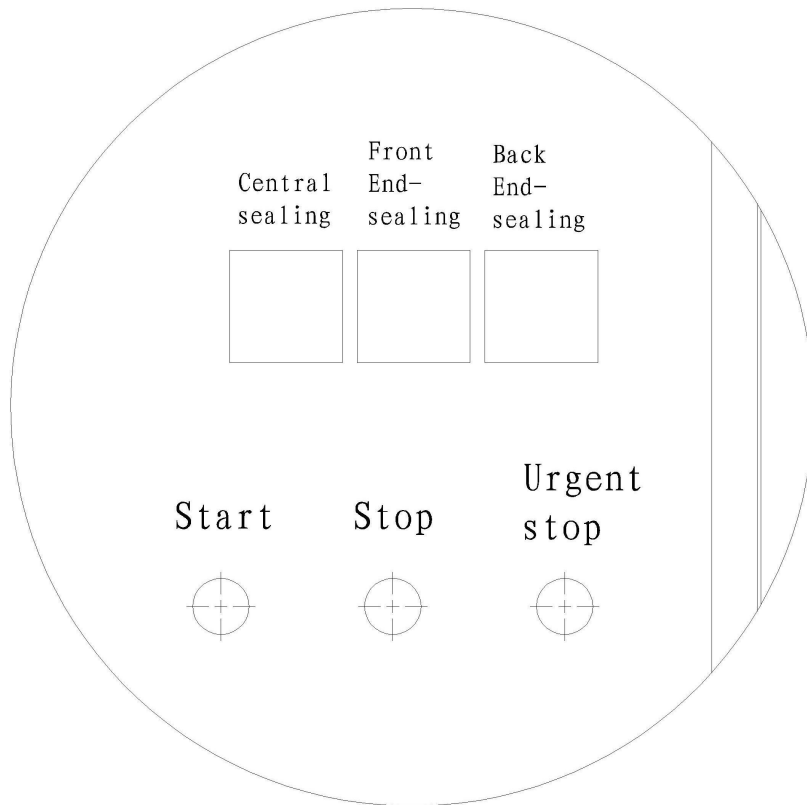

Figure-11.Control panel

(2) Menu

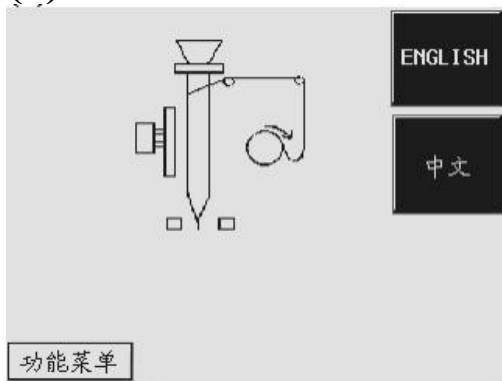
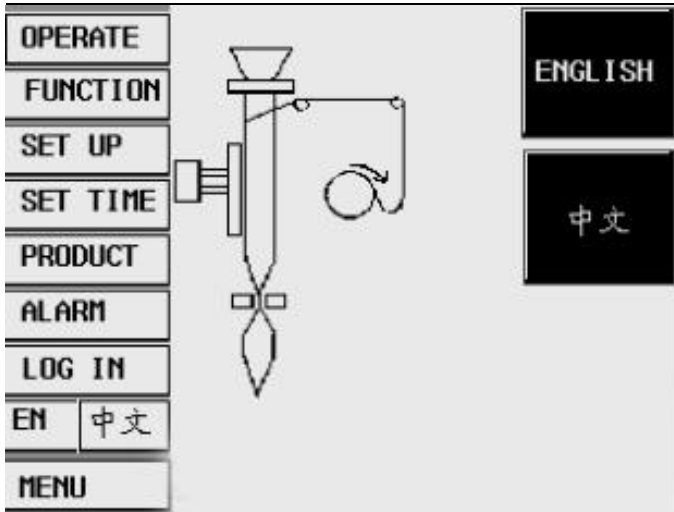

Figure-12

Touching screen: set and display the machine's parameters. After starting, this picture shows (Figure12), press "**Menu**" to shift to Figure 13

OPERATION MANUAL



Press “**Menu**”, and then enter “**Log in**” to shift to Figure 13.

Figure-13

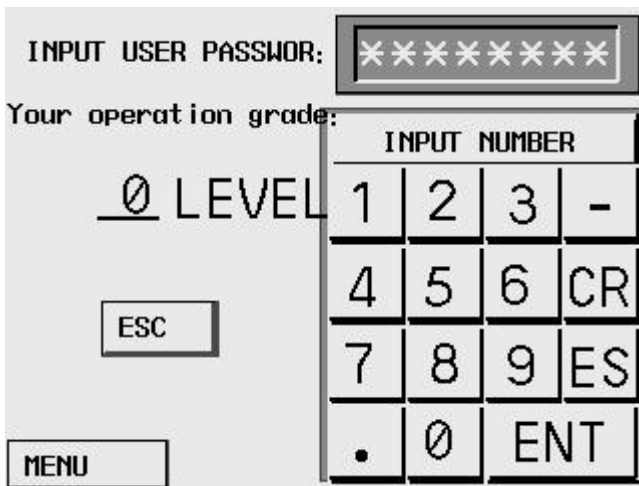

Log in

First press the number on keyboard, input correct password, and then press “**ENT**” button. Press “**ESC**” to Figure14.

First class secret: 8888

Second class secret: 9999

Figure-14



Running picture

After all the function setting, then enter into the “**Now Stop**” picture, and the machine begin to work. “**Produce**”, “**Motor**” and “**Stop loading**” buttons should choose to be automatic. Press “**Parameters**” shift to Figure 16

Figure-15

OPERATION MANUAL

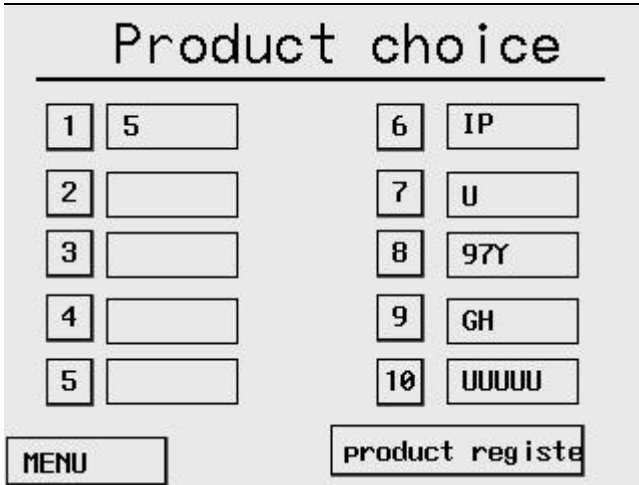

Figure-16

Product choice

For new machine, please choose its serial number, and input a name for your packing product, then press “ENT”. Meanwhile you can also set the bag length, correct the speed. Press save to keep the data. Press “ESC” shift to Figure 14. Select “Menu” shift to Figure 17

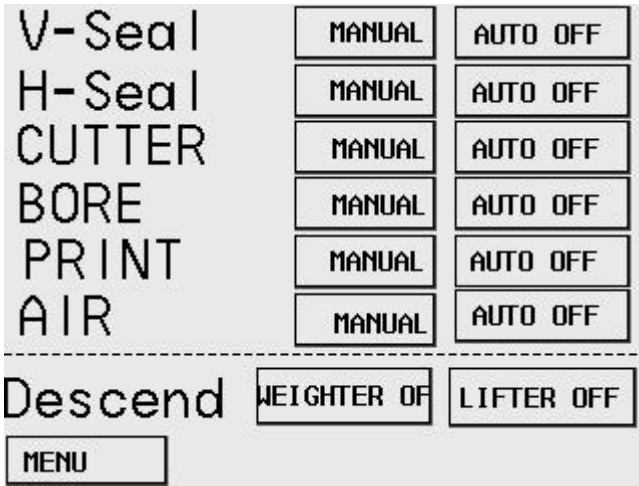

Figure-17

Function

For function choosing, should select “Auto”. Dark button shows the automatic function, if the button turns light, inactive. Press ESC to Figure14, and “Set up” to Figure 18.

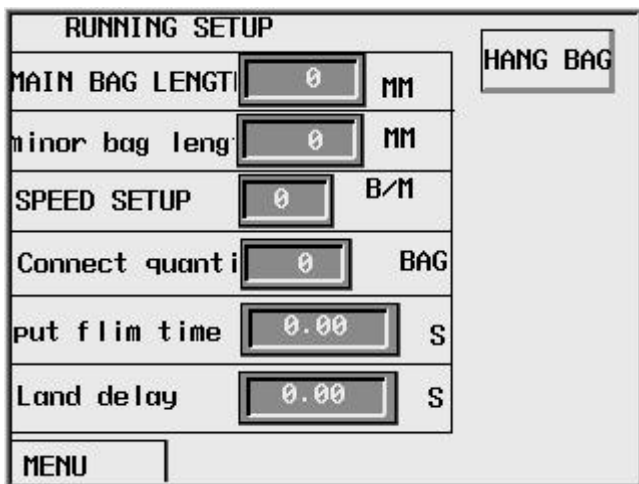

Figure-18

Set up

Set the actual length, speed and quantity of packing bags, and input their numbers directly. Press ESC to shift to Figure 14, choose “Set time” to Figure 19.

OPERATION MANUAL

	Delay time	Action time	
Prepar	0.00 e		s
V-Seal	0.00	0.00	s
H-Seal	0.00	0.00	s
CUTTER	0.00	0.00	s
PRINT	0.00	0.00	s
AIR	0.00	0.00	s
MENU			

Figure-19

Set time

Set delay time and action time which should not be too long, then it'll affect the whole running speed of the machine. If encounter leaking air due to film or lower temperature, please adjust the every sealing mouth temperature firstly, then consider prolonging the action time. Press "ESC" to Figure 4 after finishing set. Select "Running Picture" (Figure 14) to set the time.

Time setting

Bag size	Action	Delayed time	Action time
80-130 mm	Central sealing	0.25-0.30	0.25-0.30
	End sealing	0.25-0.30	0.25-0.30
	Cutter	0.20-0.15	0.20-0.15
130-220 mm	Central sealing	0.30-0.35	0.30-0.35
	End sealing	0.30-0.35	0.30-0.35
	Cutter	0.25-0.15	0.25-0.15
220-320 mm	Central sealing	0.35-0.45	0.35-0.45
	End sealing	0.35-0.45	0.35-0.50
	Cutter	0.30-0.20	0.30-0.20

Notes: The above is not the absolute time. In case of any leak by the material or low temperature, first adjust the seal temperature and then consider to increase each delayed or action time.

OPERATION MANUAL



Alarm picture

If any failure of the machine, the Figure19 will automatically set on. After getting rid of the problem, press **RESET** to running picture to make the normal work.

Figure-20

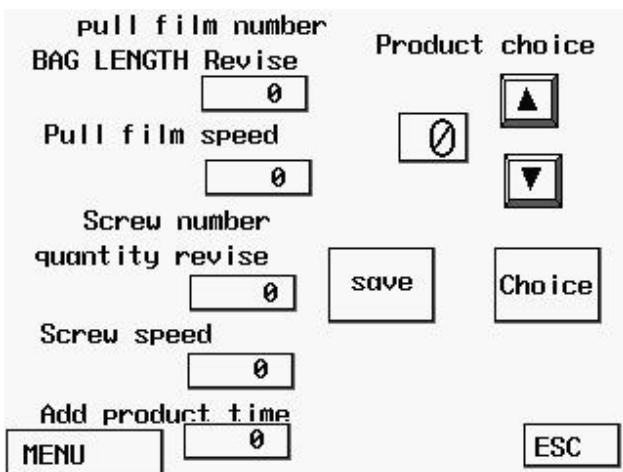

Screw parameters

Adjust for bag length, speed for pulling film. The speed for pulling film is 10-99. Meanwhile set the weight,whirling speed and filling time for the Screw weigher.

Figure-21

(3) Install and debug the packing film

1. Loading the film

A. Load the packing film on the roller, with the exit to counter-clockwise.

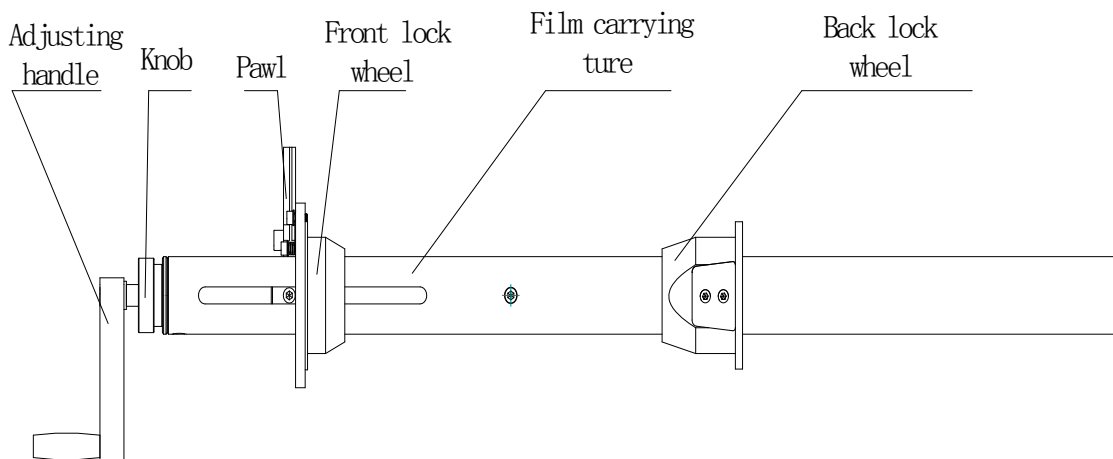

Figure 22 .Film carrying tube

OPERATION MANUAL

Operation method:

As in Figure 22, loosen the locknut to turn hand wheel counter-clockwise, in order to wider the distance between the front and back lock wheel. Take off the front lock wheel, incline back pendulum bar unit, and then load the packing film on the film carrying tube. Then, install the front lock wheel to let its detent into the groove of film roller and also between the direction block and the front lock wheel. Load the hand wheel and turn it counter-clockwise, and put the film in the middle of the film carrying tube automatically, then, firmly clock the locknut and lay back the pendulum bar unit to the original position.

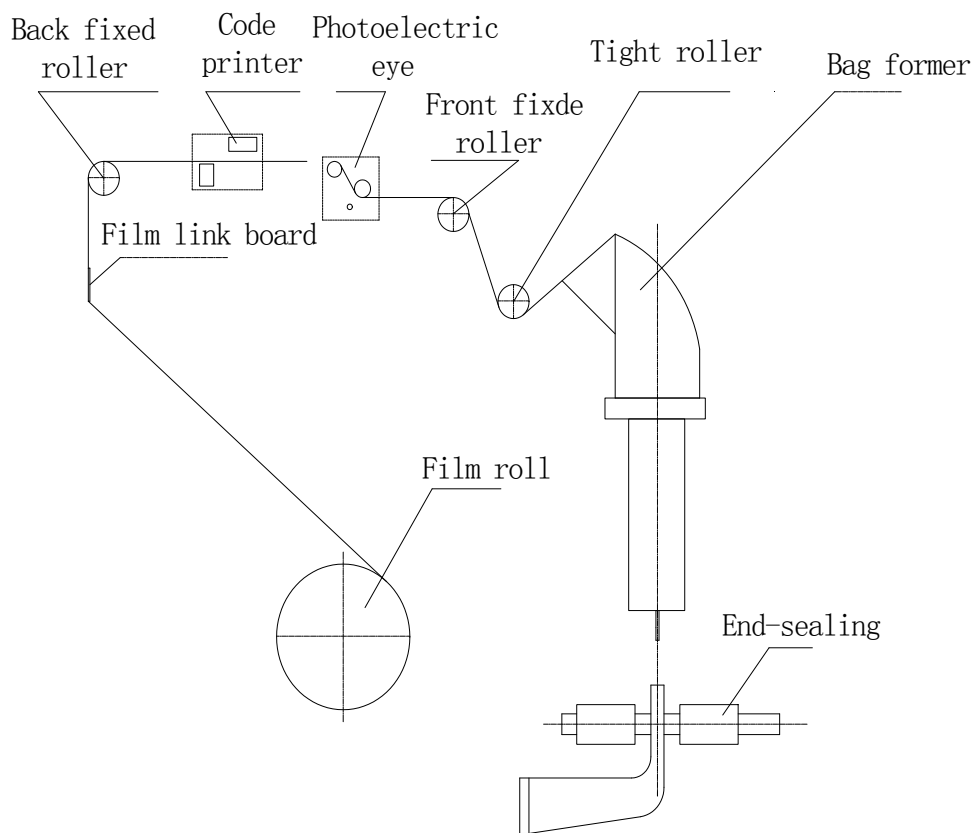

Figure-23、 Film sending and forming

B The film moves as shown in Figure23. Drill the film through connecting board first, then through the back roller, code printer, photoelectric eye, front fixed roller and tight roller, at last through bag former and then draw the film to the seal.

OPERATION MANUAL

2. Regulating paper tensility

During the film passing through bag former, if the tensility isn't equal, it will cause uneven film loading. So please adjust first and then start the machine. Methods as follows:

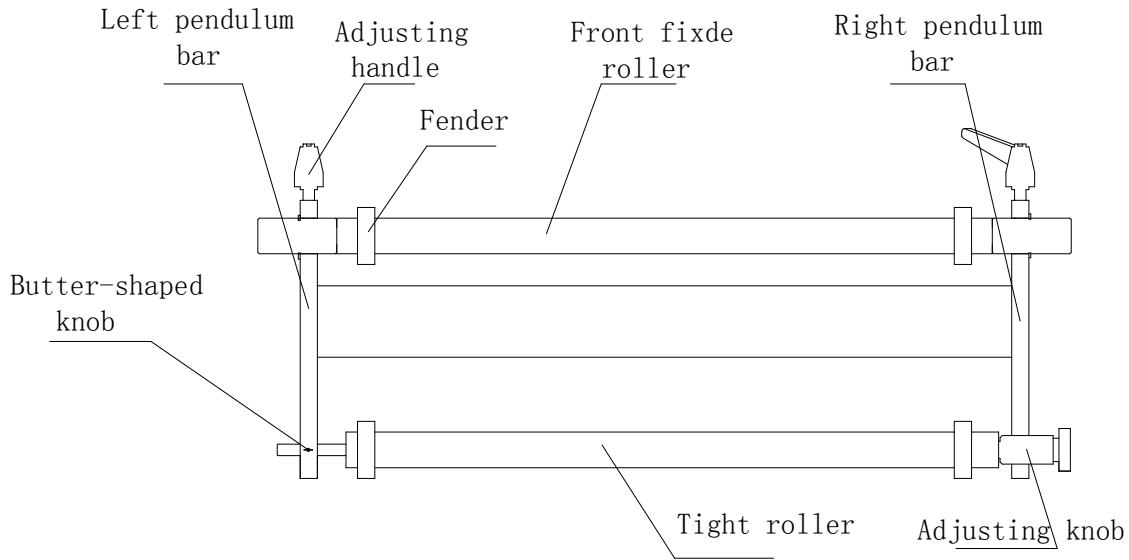

Figure-24、 Front pendulum bar unit diagram

As shown in Figure 24, first loosen left and right adjusting handle, turn the pendulum bar forward or backward to change the relative position between tight roller and bag former, so as to achieve the even tensility. At last firmly clock the adjusting handle.

In normal condition, the film in tight roller should between left and right fenders, and the film center should be in the same plane with symmetric center line of bag former. If not, it needs to adjust the tight roller. The methods for adjustment: first loosen the left butterfly-shaped knob, turn the right adjusting knob clockwise or counter-clockwise till the film center line move left or right to be in the same plane with bag former center. At last, firmly tighten the butterfly-shaped knob.

OPERATION MANUAL

3 Adjusting central sealing

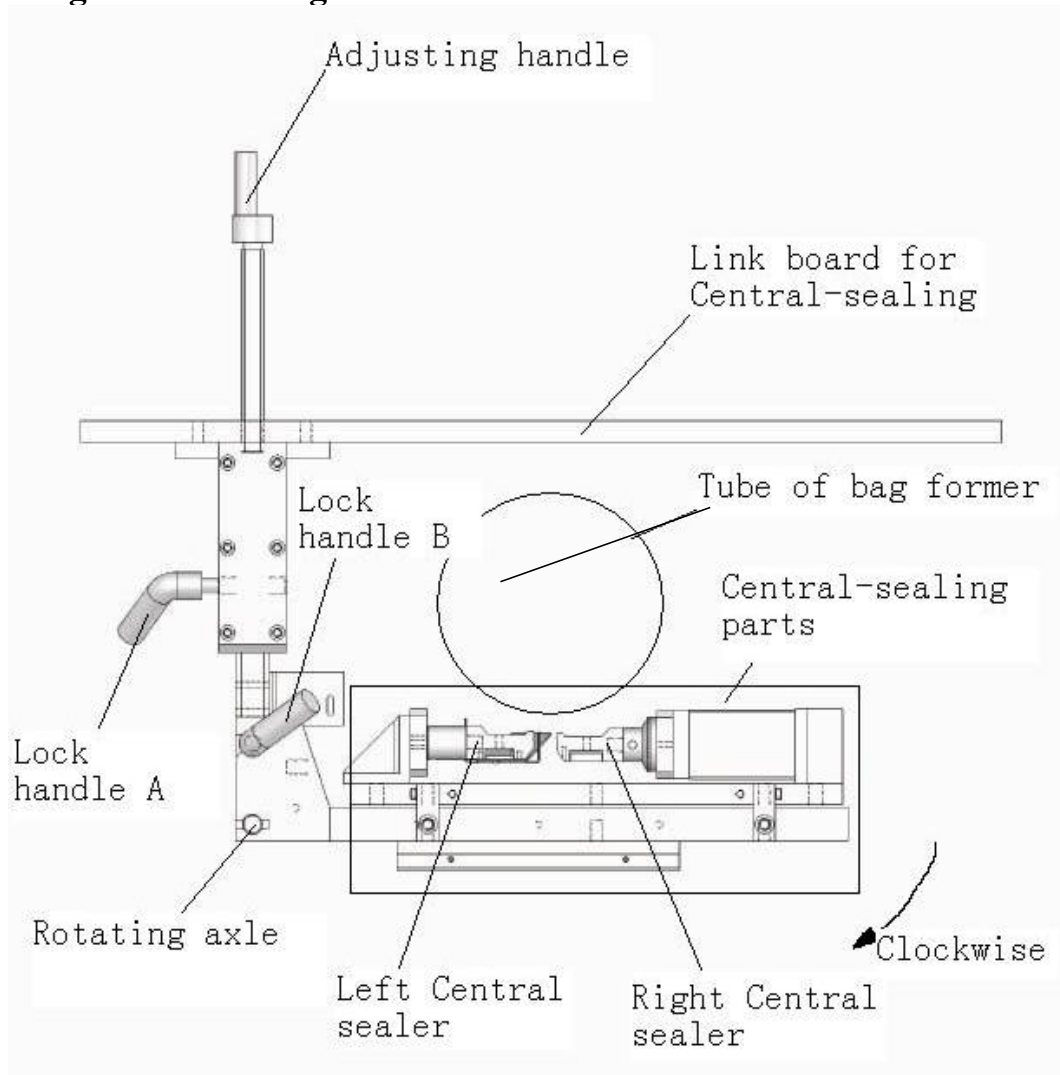

Figure-25 Central sealing structure

The effect of central sealing is no leak and clear veins. In normal working condition, only need to adjust relative position between central left or right sealer and bag former according to film size. Generally it is 2mm (refer to Figure 25). Methods for adjustment: first loosen lock handle A, turn the handle clockwise or counter-clockwise till the distance between central left or right sealer and bag former is nearly 2mm, at last tighten handle A.



Attention: Central sealing unit of the machine has already been carefully adjusted and strictly inspected before delivery; no adjustment shall be made generally

OPERATION MANUAL

4. Photoelectric eye tracking system

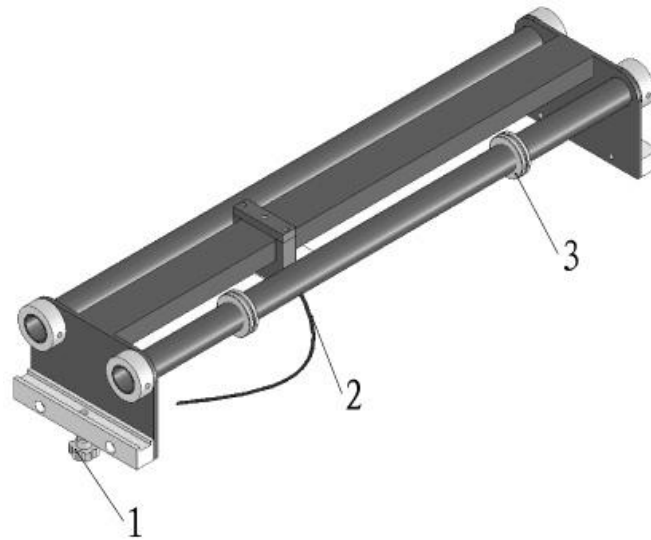

1—Photoelectric eye 2—Fender 3—Handle

Figure-26 Photoelectric eye tracking system

After setting the film length, adjust the photoelectric eye and set the cutter's position well (when two end sealers clench, it is right to cut in color code), loosen lock handle (refer to Figure 26), move photoelectric eye tracking system along guide wheel, move the bracket along its guide line so as to make photoelectric eye point meets the color code. At last tighten the lock handle.

5. Notes for adjusting bag former

The adjustment impact of bag former directly affects the bagging quality as well as the loading effect.. In changing for different packing widths, only need to load relative bag former units instead.



Note: Bag former units of the machine have already been carefully adjusted and strictly inspected before delivery; no adjustment shall be made generally

OPERATION MANUAL

6. Notes for end sealing

Because of the high temperature of end sealer, film shall be easy to adhere to the sealing surface. If not clean it immediately, it will cause air leaking. So it needs to clean up the end sealing parts frequently. Front and back sponge-pressing position is related with your willing to inflate or exhaust the bag. So if you want to inflate the bag, load front and back pressing sponge on the upper surface of sealer link base; if exhaust, on the lower surface then.

7 .Adjustment for vertical sealing guider

Drag the Vertical sealing guider by hand, and put the vertical sealing part pointing at the fixed side. Then replace the guider to press the vertical sealing tightly.

Request : A point is far from the down-hopper of the bag former 2mm

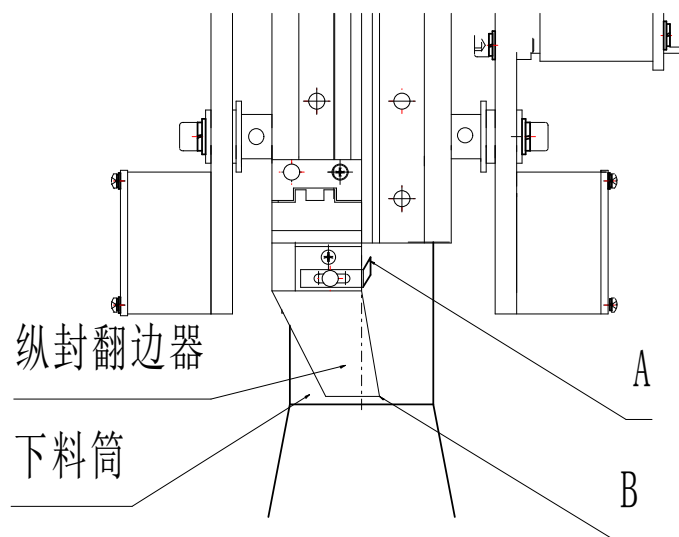

Figure-27 Guider adjustment diagram

8 Adjustment for printing date

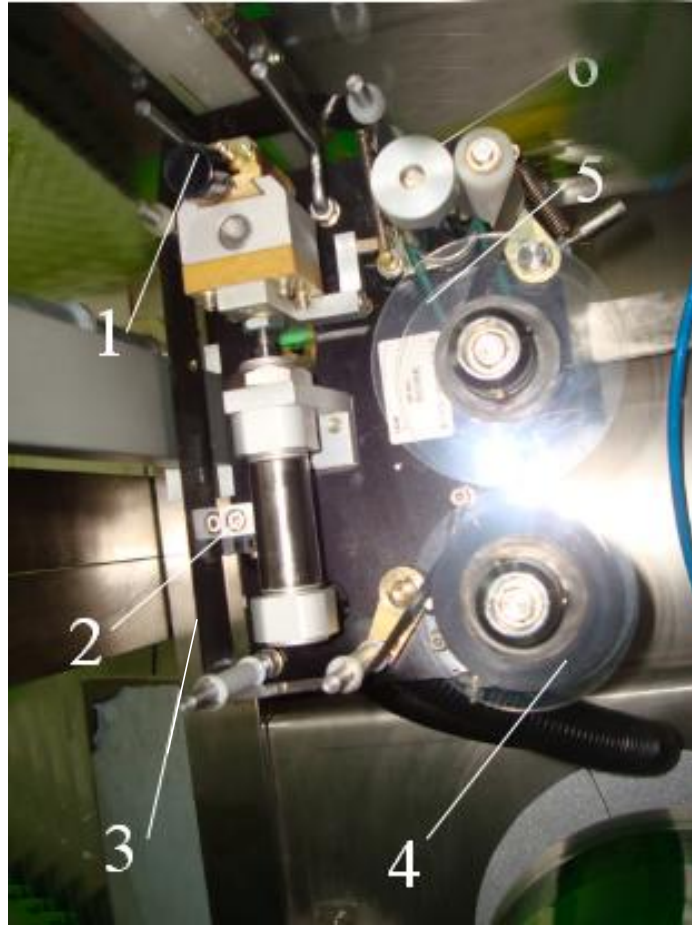

Figure-28 Printer diagram

1—Printer head 2—Cylinder 3—Ribbon spindle 4—Driven ribbon wheel-cover
5—Initiative ribbon wheel-cover 6—Ribbon-dragging wheel

- 8.1 Use thermo print with carbon belt for the date printer, and have two rows for alphabets/characters. Every row has 12 alphabets/characters
- 8.2 Control the print pressure via adjusting the air-entry capacity from cylinder, in order to make print words clear without breaking the film.
- 8.3 Adjust the date print position through shifting the printer unit frontward and backward. Then lock it to avoid moving.
- 8.4 Change the ribbon according to the following steps after using up the ribbon: firstly take off the 4-Driven ribbon wheel-cover and 5-Initiative ribbon wheel-cover, then change it. Please install the ribbon as per to the above picture, and fix the top-cover

五 .Regular start

After the above adjustments, this machine will be in normal working condition. However, it also needs some more inspections and trial run before production.

1 Safety inspection

First, to check if there is any impurity on the conveyer belt, operating surface and end sealing tool carrier, second, to make sure no other people operating the machine.

2 Turn on the power switch and heating switch

Turn on the power switch and heating switch, and check the temperature shown on every temperature controller. Heating temperature shall change according to the different film material, packing speed and the inner environment.

3 Install film roller

Adjust the film to center on the tight pendulum bar. And adjust central sealing parts to make a distance about 2mm with bag former tube, then adjust the photoelectric eye.

4 Trial run

- * Set bag length on “Running picture”, the length is the distance between two color codes.
 - * Choose Auto on “Function” of “Running picture”.
 - * Set “Time setting”.
 - * Choose the photoelectric eye buttons of “Empty”, “Running” and “Motor”.
- If no color signal, “Failure” will be shown, and the machine will stop automatically and need to adjust photoelectric eye again.
- * If adjust cutting position again, move the photoelectric eye bracket forward and backward as displayed in Figure 16.
 - * After adjustment, enter into normal work.



Attention: Don` t use alcohol to spray or others, that` ll break the surface



Attention: Please be cautious to the fire when using alcohol or petrol those kind

OPERATION MANUAL

of easy burning detergent

六 .Maintenance and service

1 .Daily maintenance and clean

- (1) Clean the machine each time after packing.
- (2) Turn off the power and make sure the cold heating parts before cleaning.
- (3) Main parts need to be cleaned
 - * Remove the product chips on the convey line by compressed air or other ways.
 - * Brush the film chips that adhere to the sealing surface by wire brush with silicon oil.
 - * Clear the dirt on the control panel, protection cover and painted surface with soft cloth.

2 .Monthly maintenance and inspection

- (1) Add lubricant to the bearings on sealing parts.
- (2) Add lubricant to the chains of driving unit.
- (3) Check if there is any loose in chains and belts of driving unit, if some, tighten it.
- (4) Check if there is any loose in bolt or nut of each part, tighten the loosed one.

3. Related inspections once half a year

- (1) Check if there is any wear in the belt (triangle belt and film belt) of driving unit, if serious, please change it.
- (2) Check all wearing parts, change in time.
- (3) Check the fastness of the wirings on electrical terminal plate, and tighten the loosed one. Check if there is any dust or dirt on electric element and circuit board, remove them by clean and dry compressed air.

OPERATION MANUAL

七 .Troubleshooting

Failure	Reason	Remedy
Out-of-position of photoelectric eye	(1) Improper bag length (2) Too dirty tight roller (3) Photoelectric eye doesn't function.	(1) Reset bag length. (2) Clear tight roller. (3) Check color code; adjust the distance between electric eye and film or sensitivity knob. The light turns off while color code aiming at it, otherwise turns on.
Leakage from sealing or broken film	(1) Excessively high or low temperature (2) Dirty tool carrier (3) Front and back sealer in bad position (4) Poor quality film	(1) Adjust the temperature. (2) Brush the dirt on tool carrier by wire brush with silicon oil. (3) Reset the tool carrier. (4) Change the film.
The temperature controller can't control temperature or has no display	(1) Damaged heating unit (2) Damaged solid relay (3) Damaged thermal couple (4) Loose plug (5) The temperature controller is damaged because of excessively high or unstable voltage.	(1) Change heating unit. (2) Change solid relay. (3) Change the thermal couple. (4) Tighten plug again. (5) Replace the temperature controller.
Leakage from central sealing or broken film	(1) Excessively high or low temperature (2) Dirty tool carrier (3) Poor quality film	(1) Adjust the temperature. (2) Brush the dirt on tool carrier by wire brush with silicon oil. (3) Change the film.

Sincerely hopes that you will clean and maintain the machine everyday, and check it regularly to maximize its functions for safety production and long-time excellent performance. Thanks!

8.Rejection treatment

The rejection treatment of the equipments will be arranged as per the normal

OPERATION MANUAL

industrial rejection treatment.

Air-diagram -1

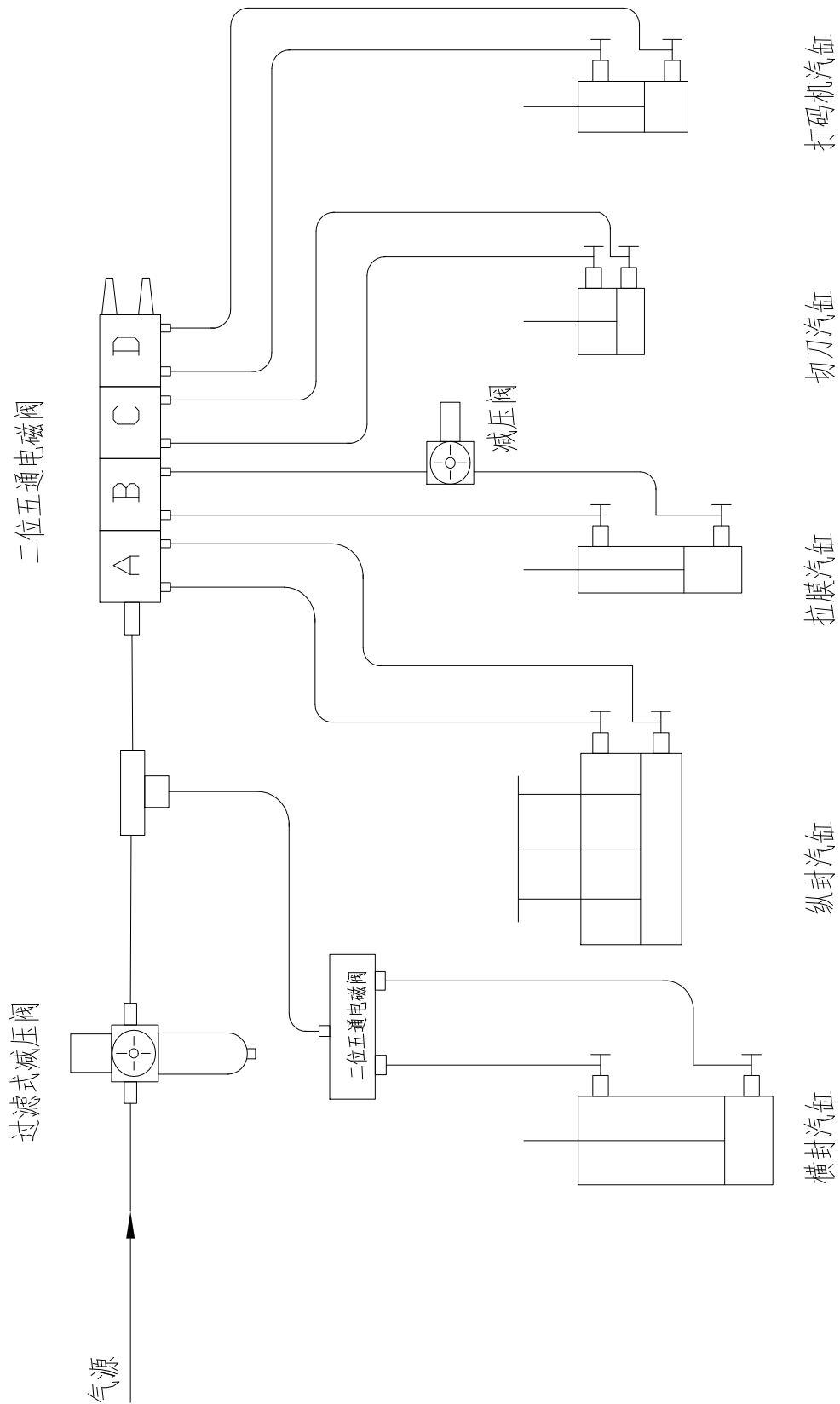

General Diagram -2

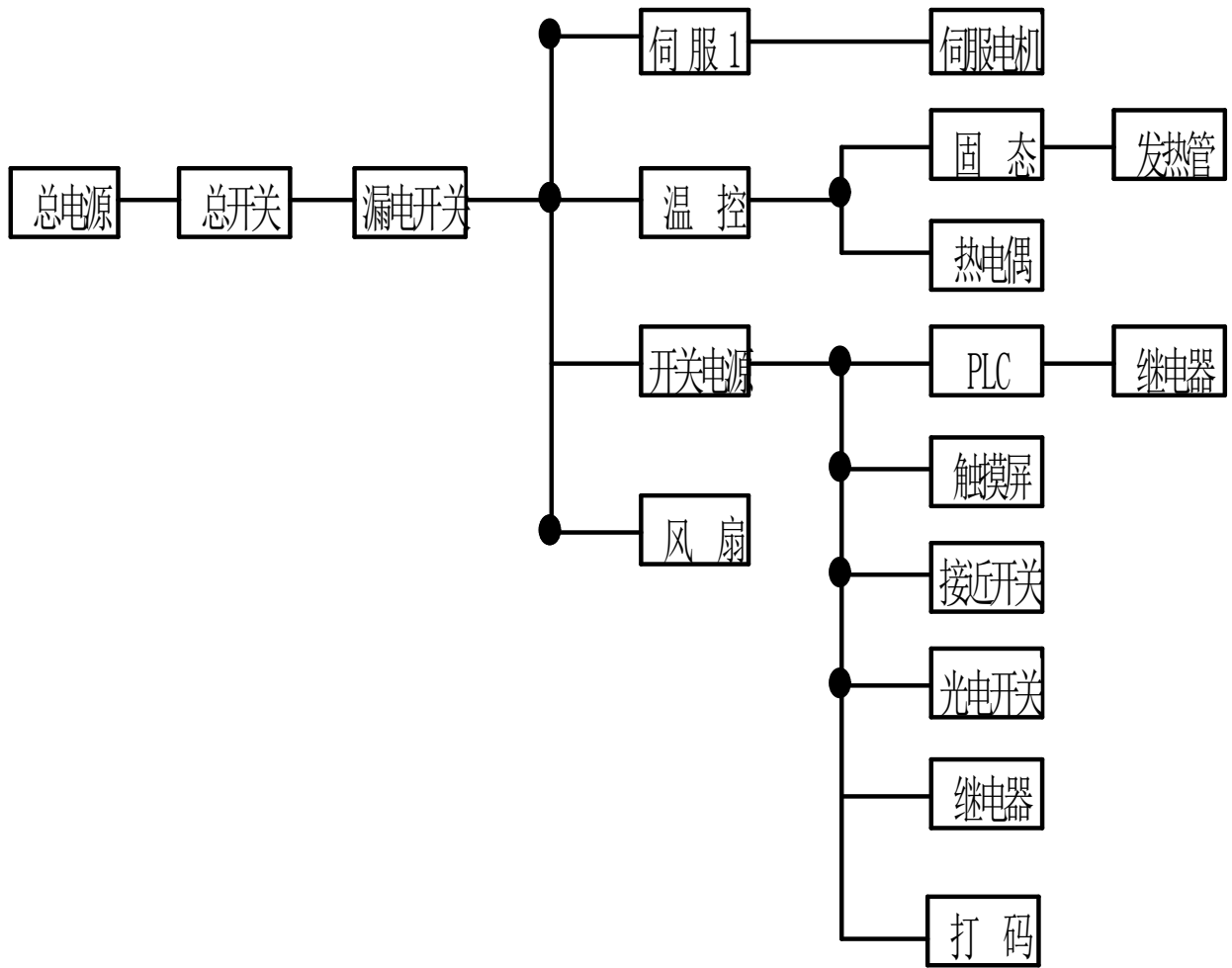

OPERATION MANUAL
